

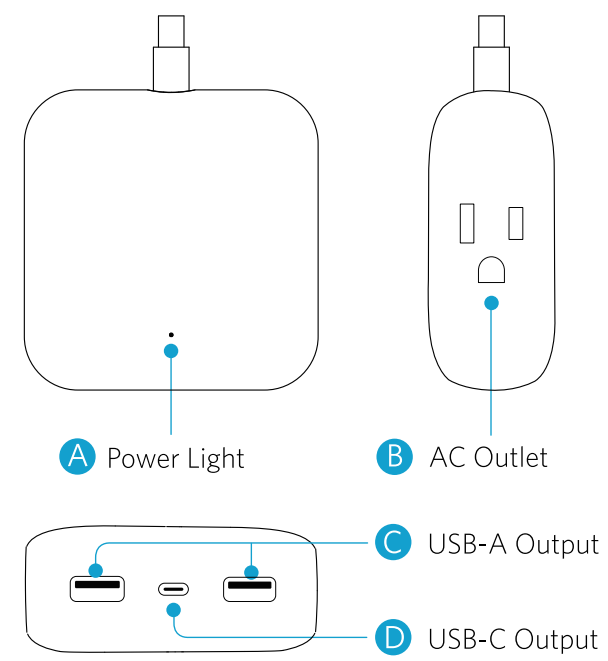

Charge Fast, Live More

PowerPort Strip PD 2 mini

Overview



Using Your PowerPort Strip

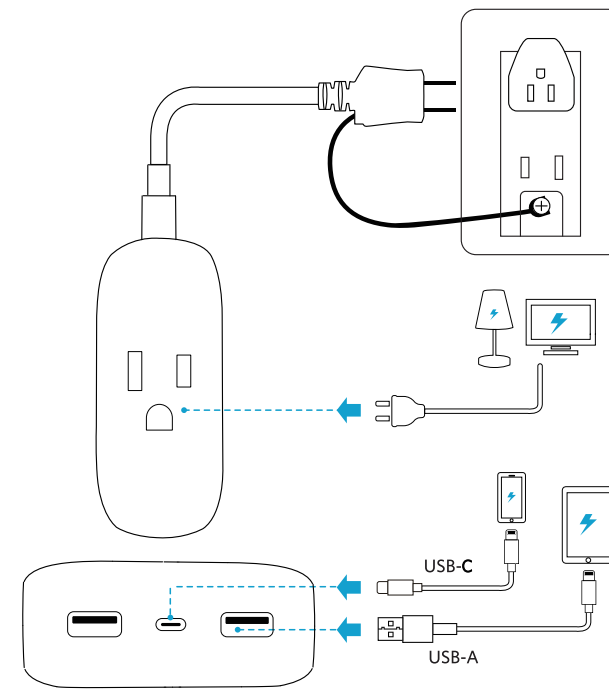

- When **PowerPort Strip** is connected to the power outlet, the Power Light is on.

Safety

- Do not connect **PowerPort Strip** to an ungrounded outlet.
- Do not use with extension cords.
- Do not exceed electrical ratings.
- Use in dry locations and indoors only.
- Install **PowerPort Strip** away from heat-emitting appliances such as radiators.
- Keep children away from **PowerPort Strip**.

Specifications

AC Input	125V AC 50/60Hz 10A
AC Output	1000W (when USB ports are not used)
USB A Output	5V \equiv 2.4A total (2.4A Max Each Port)
USB C Output	5V \equiv 3A, 9V \equiv 2A
Size	80 x 80 x 34 mm / 3.1 x 3.1 x 1.3 in
Cable Length	1.5 m / 5 ft



anker.com/support

@Anker
@Anker Japan

@AnkerOfficial
@Anker_JP

@anker_official
@anker_jp

Anker Innovations Limited
Room 1318-19, Hollywood Plaza, 610
Nathan Road, Mongkok, Kowloon,
Hong Kong

Product Number A9122
PowerPort Strip PD 2 mini
51005002553 V02

FCC Statement

This device complies with Part 15 of the FCC Rules. Operation is subject to the following two conditions: (1) This device may not cause harmful interference, and (2) this device must accept any interference received, including interference that may cause undesired operation.

Warning: Changes or modifications not expressly approved by the party responsible for compliance could void the user's authority to operate the equipment.

Note: This equipment has been tested and found to comply with the limits for a Class B digital device, pursuant to Part 15 of the FCC Rules. These limits are designed to provide reasonable protection against harmful interference in a residential installation.

This equipment generates, uses, and can radiate radio frequency energy and, if not installed and used in accordance with the instructions, may cause harmful interference to radio communications. However, there is no guarantee that interference will not occur in a particular installation. If this equipment does cause harmful interference to radio or television reception, which can be determined by turning the equipment off and on, the user is encouraged to try to correct the interference by one or more of the following measures:

- 1) Reorient or relocate the receiving antenna.
- 2) Increase the separation between the equipment and receiver.
- 3) Connect the equipment into an outlet on a circuit different from that to which the receiver is connected.
- 4) Consult the dealer or an experienced radio / TV technician for help.

The following importer is the responsible party.
Company Name: Fantasia Trading LLC
Address: 5350 Ontario Mills Pkwy, Suite 100, Ontario, CA 91764
Telephone: +1 (800) 988 7973

ISED Compliance Statement

This device contains licence-exempt transmitter(s)/receiver(s) that comply with Innovation, Science and Economic Development Canada's licence-exempt RSS(s). Operation is subject to the following two conditions:

1. This device may not cause interference.
2. This device must accept any interference, including interference that may cause undesired operation of the device.

Cet équipement est conforme aux limites d'exposition aux radiations FCC/IC établies pour un environnement non contrôlé. Cet équipement doit être installé et utilisé avec une distance minimale de 20 cm entre le radiateur et votre corps.

L'émetteur/récepteur exempt de licence contenu dans le présent appareil est conforme aux CNR d'Innovation, Sciences et Développement économique Canada applicables aux appareils radio exempts de licence. L'exploitation est autorisée aux deux conditions suivantes :

1. L'appareil ne doit pas produire de brouillage;
2. L'appareil doit accepter tout brouillage radioélectrique subi, même si le brouillage est susceptible d'en compromettre le fonctionnement.

概要

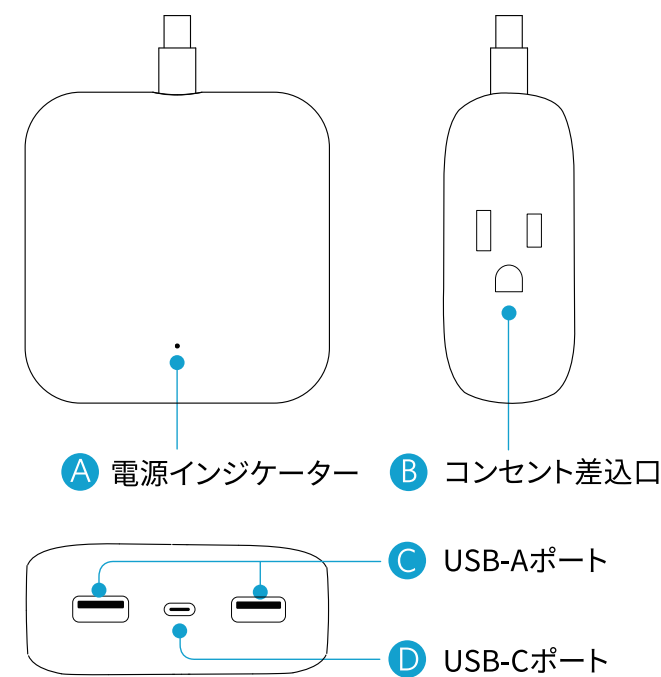

本製品の使用方法

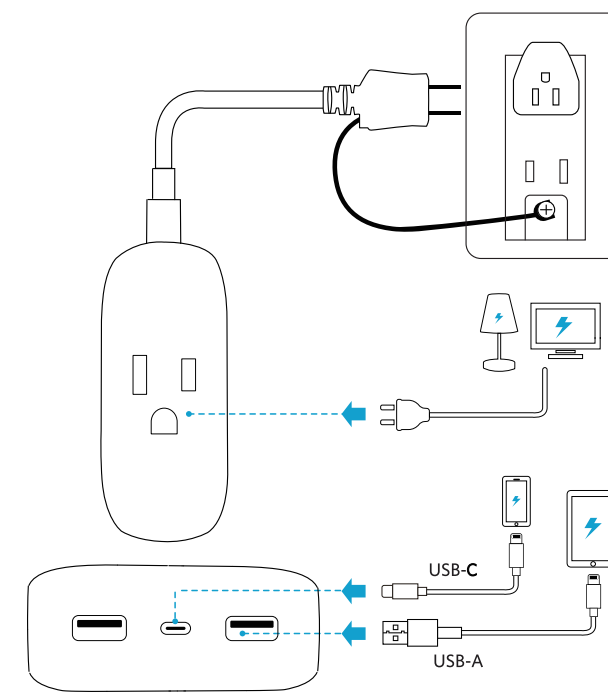

- 本製品が電源コンセントに接続されると、電源インジケータが点灯します。

安全に関する注意事項

1. 本製品はデジタル機器との接続向けに設計されています。
2. 本製品をご使用の際は、周辺温度を25℃以下に保ってください。
3. 本製品を火気の近くで使用・保管しないでください。
4. 電源をオフにする場合は、本製品をコンセントから抜いてください。
5. コードや電源プラグが破損している場合は、本製品の使用を中止し、カスタマーサポートへご連絡ください。
6. お手入れは、乾いた布、もしくはブラシで行ってください。
7. 本製品はコンセントの近くに設置し、手の届きやすい状態にしてください。
8. 本製品が破損したり部品が脱落した場合には、カスタマーサポートへご連絡ください。
9. 漏電事故防止のため、接地接続(アース)を行ってください。アース線(接続線)をとりつけない状態で接続すると、感電・火災の恐れがあります。
10. 電源タップを数珠つなぎにする「たこ足配線」や「二度接続」はしないでください。発熱、発火の原因となります。
11. 充電の際に接続端子に触れないようにご注意ください。感電・発火・傷害・故障の原因となります。
12. 本製品に記載されている電流許容量を超えないように、電気製品を接続してください。電流容量を超えた場合、火災や故障の原因となります。

仕様

AC定格電圧・電流	125V AC 50/60Hz 10A
AC定格消費電力	1000W (USBポート不使用时)
USB-A出力	合計 5V ≒ 2.4A (各ポート最大2.4A)
USB-C出力	5V ≒ 3A, 9V ≒ 2A
サイズ	約 80 x 80 x 34 mm
ケーブルの長さ	約1.5m

カスタマーサポート

ES: Servicio de atención al cliente



通常保証18ヶ月(延長あり)

ES: Garantía limitada de 18 meses



テクニカルサポート

ES: Soporte técnico ilimitado



support@anker.com



(日本) 03 4455 7823 月-金 9:00 - 17:00